

ingenico

# AXIUM DX8000-BASE-W1

## User Guide

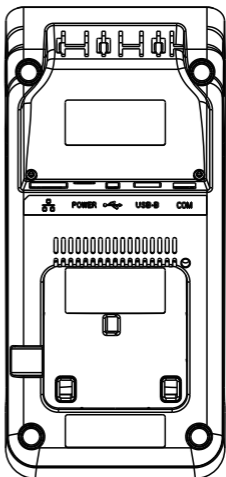
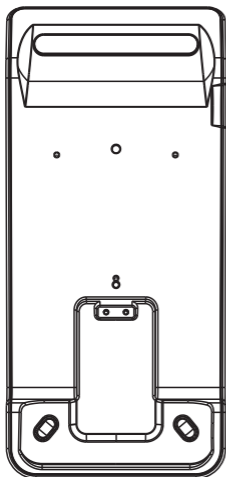

[www.ingenico.com](http://www.ingenico.com)

13-17 rue Pagès, 92150 Suresnes – France

Banks and Acquirers International Holding, SAS / 814 767 216 RCS Nanterre



UYS01000570



# Contents

Table of Contents .....	2
1. Product Introduction .....	3
1.1 What's in the Box – subject to ordered product configuration .....	3
1.2 Device Layout .....	3
1.3 Interface definition .....	4
2. Product Technology Features .....	4
2.1 Product Technology Specifications .....	4
2.2 Environmental Conditions .....	5
2.3 Product Functions .....	5
3. WiFi connection .....	5
3.1 Connect DX8000 to the base WiFi .....	5
3.2 Web Setting of base .....	6
3.3 Restore factory Setting .....	8
4. Pairing connection .....	8
4.1 Prepare for Base Pairing .....	8
4.2 Pair method .....	9
4.3 Unpair method .....	9
4.4 Ethernet Parameter Setting .....	10
4.5 WLAN Parameter Setting .....	11
4.6 Advanced Setting .....	11
4.7 Base Operating Modes .....	12
4.7.1 Gateway / Router Mode – Default Operating Mode .....	12
4.7.2 Bridge Mode - (Also known as Access Point Mode) .....	12
4.7.3 WiFi Repeater Mode .....	12
4.8 Management Setting .....	13
4.8.1 Upgrade the firmware of base .....	13
4.8.2 Save the setting of base .....	14
4.8.3 Load the setting of base .....	14
5. Fixing of the base .....	14
6. FAQs .....	16
7. Notes .....	17
8. Delivery and Storage .....	17
9. Power Adapter .....	17
10. Standard .....	17

# 1. Product Introduction

## 1.1 What's in the Box – subject to ordered product configuration

Open the package to check if there are any disabling masks or transportation damage in the terminals and fittings.

Procedures:

1) Open the package.

2) Check the following items(Subject to actual product configuration):

- Base host.
- Product instruction.
- USB type-C cable
- 5V 2A Power adapter
- AC transfer head for EU
- AC transfer head for UK
- AC transfer head for UL

3) Save the transportation package and packing material for second use.

## 1.2 Device Layout

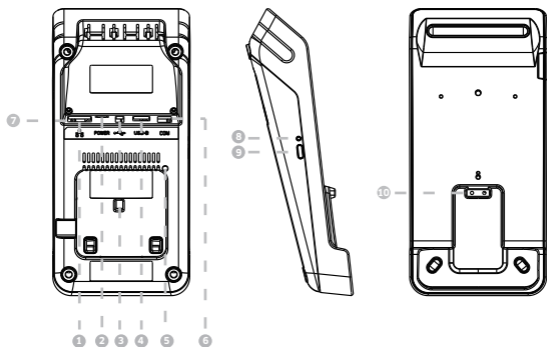

1. RJ45 Network Interface	2. USB-TYPE C Power Interface	3. USB-TYPE A
4. USB-TYPE B	5. Reset Button	6. RJ22 Serial Interface
7. Network LED link & active	8. Two color Indicator lights	9. Pairing Button
10. DX8000 Charging Contact		

## 1.3 Interface definition

### 1) RJ45 interface



Sequence	RJ45 Signal
1	ETH_TX+
2	ETH_TX-
3	ETH_RX+
4	NC
5	NC
6	ETH_RX-
7	NC
8	NC

### 2) USB-TYPE A interface

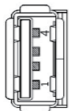

Sequence	USB-TYPE A Signal
1	VBUS 5.0V
2	D-
3	D+
4	GND

### 3) USB-TYPE B interface

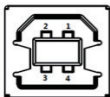

Sequence	USB-TYPE B Signal
1	Not connect
2	D-
3	D+
4	GND

### 4) RJ22 Serial interface

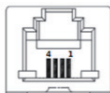

Sequence	RJ22 Serial Signal
1	Not connect
2	UART_TX*
3	UART_RX *
4	GND

\* RS232 level

## 2. Product Technology Features

### 2.1 Product Technology Specifications

Port	a USB type-C power port a RJ45 network port a RJ22 serial port
Power	USB HOST output: 5.0V DC 0.5A Charge output: 5.0V DC 1A, when USB HOST is working. 5.0V DC 1.5A, when USB HOST is not working.
Size and Weight	Size: 193.8mmx89mmx38.6mm Net Weight: 0.18kg

## 2.2 Environmental Conditions

Environmental conditions for running, storing and delivering the product:

Temperature	Running	0°C ~ 40°C
	Storage and Delivery	-20°C ~ 70°C
Humidity	Running	10 % ~ 90%
	Storage and Delivery	5 % ~ 90% ( 40°C)
Atmospheric pressure		86kPa ~ 106 kPa; Below 2000 meters above sea level

## 2.3 Product Functions

The base has three main functions as below:

- DX8000 charging : Connect the base with the power adapter, then place DX8000 on the base to get charged.
- Serves as extended communication ports of DX8000: Network port, serial port, USB port, etc.
- Typical applications: Enables DX8000 to communicate with host computer via serial port, and get Ethernet through Network port.

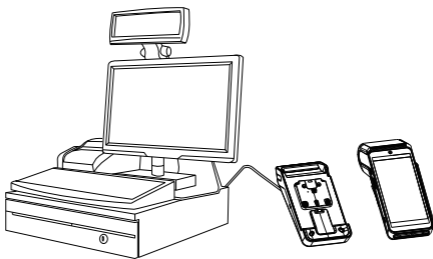

# 3. WiFi connection

## 3.1 Connect DX8000 to the base WiFi

- Power on the base.
- Click "Settings" menu on DX8000 , and then click "Base" [step 1]
- Click the "scanning box" [step 2], and scan the Data matrix code label on the back of base. On the Pop-up menu, we can choose "Only use base wifi" . [step 3]
- After that , we can get the "Successfully Connected" status.[step 4]

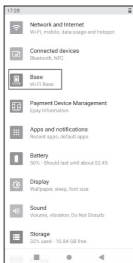

【Step1】



【Step2】

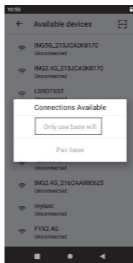

【Step3】

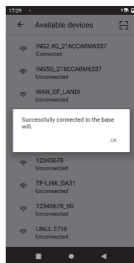

【Step4】

## 3.2 Web Setting of base

The base can be set from the web.

- Use a computer to connect the base via WiFi.
- The web setting IP of base is 192.168.47.1. Login name is Admin.  
Password is the Pairing Password.  
(Pairing Password please refer to the rear label for details)
- User can get the status of base on the status page.

<ul style="list-style-type: none"> <li>Status</li> <li>Network</li> <li>WLAN</li> <li>Advanced</li> <li>Message</li> </ul>	<p><b>System Status</b></p> <p>Up time: 0day0h:1m41s Firmware Version: v5.4.116-1.0.BG</p> <p><b>WAN Status</b></p> <p>WAN MAC: 4c:91:57:21:7297 IP: 172.28.18.37 Subnet Mask: 255.255.255.0 Default Gateway: 172.28.18.1 DNS Server: 10.10.16.66, 10.10.16.67</p> <p><b>2.4GHz WLAN Status</b></p> <p>MAC: 4c:91:57:6d:7e:16 SSID: ING2_4G_211CA0000401 Encryption: WPA2-PSK Channel: 6 Mode: 2.4 GHz (B+G+N)</p> <p><b>5GHz WLAN Status</b></p> <p>MAC: 4c:91:57:72:71:58 SSID: ING5G_211CA0000401</p> <p style="text-align: right;">Refresh</p>
--	--

**WAN Setting** LAN Setting

WAN Type Select:  PPPoE  DHCP  Static IP

This page is used to configure the parameters for Internet network which connects to the WAN port of your Access Point.

IP:

Subnet Mask:

Default Gateway:

Primary DNS:

Secondary DNS:

Apply Save Refresh

- User can get and change the Ethernet parameter on the Network page.

**2.4GHz WLAN** 5GHz WLAN WLAN Clients

SSE:

Hidden SSE:  Enable SSE will not be discovered by scanning after hiding

Channel:

RF Power:

Send Width:

Wlan Encryption:

Personal (Pre-Shared Key):  (8-63 ASCII characters)

Apply Save Refresh

- User can get and change the WLAN parameter on the WLAN page.

**Operating Mode** DMZ Setting Static DHCP

Operating Mode:  Gateway Mode  
Normal router working mode, NAT is enabled and clients share the same IP Address to the ISP via the WAN port.

Bridge Mode  
Ethernet and wireless interfaces are bridged together and the NAT function is disabled.

WPA Repeater Mode  
Ethernet and wireless interface are bridged together and the wireless will connect to Repeater AP.

Apply Save Refresh

- User can change the operating mode, enable DMZ or set static DHCP on the Advanced page.

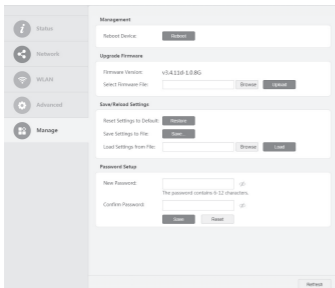

- User can update the firmware of base, save and reload the settings, change the password on the Manage page.

### 3.3 Restore factory Setting

- Use paperclip to click the RESET button 3 seconds to restore the factory setting of the base.
- The position of RESET button is below.

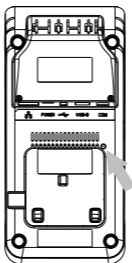

## 4. Pairing connection

- If DX8000 want to use the USB ports or RJ22 serial port on the base, it should be paired to the base.

### 4.1 Prepare for Base Pairing

- Only one DX8000 can use the USB ports and RJ22 serial port of the base at the same time.
- If the red indicator light is on, it indicates the base is available for pairing.
- If the green indicator light is on, it indicates the base is successfully paired. If the base



is to be paired with another DX8000, long press on the [Pairing] button to clear the pairing record . When the red indicator light is on, pair another DX8000 with the base.

- Illumination of two color indicator lights:

SN	Light Condition	Base Status
1	Red light on	Base to be paired
2	Green light flashing	Base paired but disconnected with DX8000
3	Green light on	Base paired and connected with DX8000
4	Red light flashing	Base in upgrading

## 4.2 Pair method

- First, connect DX8000 to the base via chapter 3.1 and choose "Pair base". [step1]
- After pairing, we can check the Ports and Version of base from DX8000 [Step2].

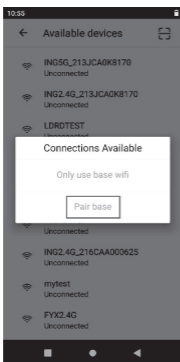

【Step1】

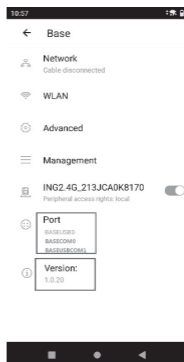

【Step2】

## 4.3 Unpair method

- Only the paired DX8000 could be unpaired with the base. When DX8000 unpairs the base, the base will change its conditions to "unpaired" with the red light on.
- Click the blue button besides the SSID [Step1]. Click "YES" [Step2] to unpair the base with DX8000:

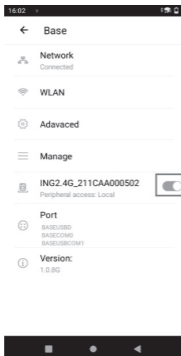

【Step1】

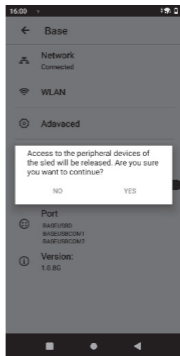

【Step2】

## 4.4 Ethernet Parameter Setting

Procedures:

- Tab on "Network" enter WAN Setting or LAN Setting menu.
- Enter WAN Setting to get and set the WAN parameter.
- Enter LAN Setting to get and set the LAN parameter.

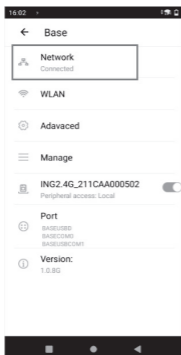

【Step1】



【Step2】

## 4.5 WLAN Parameter Setting

- Enter WLAN menu.[Step1]
- AXIUM DX8000-BASE-W1 only has 2.4G WLAN,so we can click "2.4GHz WLAN" to set 2.4G parameter. [Step2]
- We can set Channel ,RF power,band width and get WLAN MAC on the menu. [Step3]

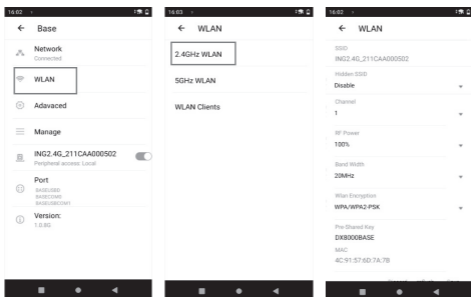

【Step1】

【Step2】

【Step3】

## 4.6 Advanced Setting

- Enter advanced menu.
- We can set the operating mode,DMZ and static DHCP of the base[Chart 1].
- In operating mode,we can set the base work in different mode [Chart 2].
- We can set DMZ[Chart 3]and add static DHCP[Chart 4].

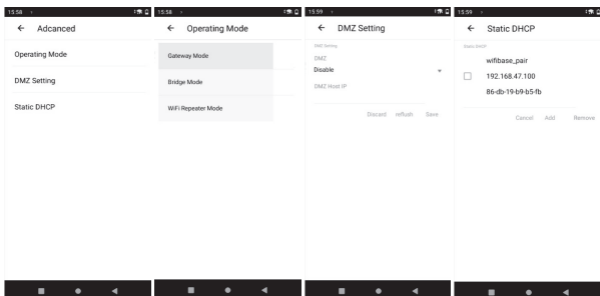

【Chart1】

【Chart2】

【Chart3】

【Chart4】

## 4.7 Base Operating Modes

### 4.7.1 Gateway / Router Mode – Default Operating Mode

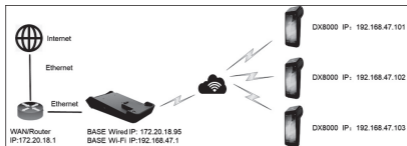

- Local router distributes a corporate IP address to the Base Station Ethernet port.
- Base distributes IP addresses to DX8000 devices via internal DHCP server.
- DX8000Base and devices are on private network segment (e.g. 192.168.47.X).
- Only the Base Station IP address is visible to and addressable by the network. All of the device private IP addresses are masked from the network by NAT.

### 4.7.2 Bridge Mode - (Also known as Access Point Mode)

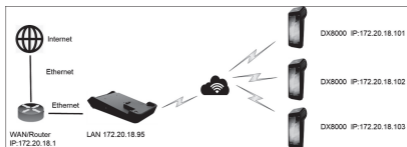

- Router distributes corporate IP network addresses to the bases and DX8000 devices.
- Base and devices are directly connected to local router and on the same network segment.
- Base DHCP server is turned off and NAT is not used.
- All device IP and MAC Addresses are visible to and addressable by the network.

### 4.7.3 WiFi Repeater Mode

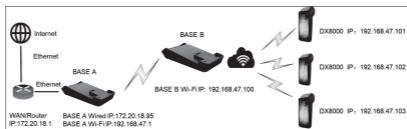

- Designed to expand wireless coverage, by connecting two bases together by Wifi.
- For example, DX8000 is too far away to connect Base A.
- Put Base B between Base A and DX8000 & Set Base B repeat the Base A.
- DX8000 can connect to internet via Base B.
- Does not operate with a Mesh network.

## 4.8 Management Setting

### 4.8.1 Upgrade the firmware of base

- First, we use software manager to install the wifidockfirmware.apk in DX8000, as follow :

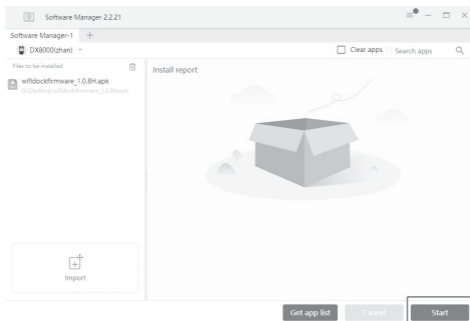

- Second, we pair the base with DX8000. Wait for upgrading. [Step1]. And get the successful tips[Step2]. Check the version of the base[Step3].



【 Step1 】

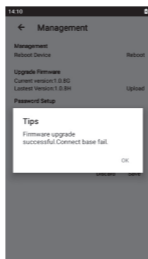

【 Step2 】

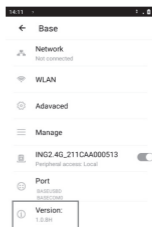

【 Step3 】

## 4.8.2 Save the setting of base

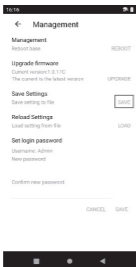

【Step1】

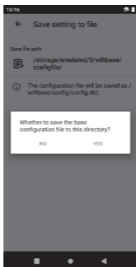

【Step2】

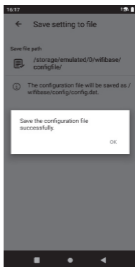

【Step3】

## 4.8.3 Load the setting of base

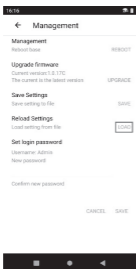

【Step1】

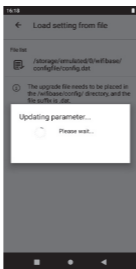

【Step2】

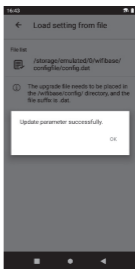

【Step3】

## 5. Fixing of the base

In some scenes, we want to fix the base and the DX8000 to the table.

The fixing structure is not standard configuration. We need to buy it from the agent.

Installation procedures as below:

- First, fix the space block on the table with screws.
- Second, fix the Base Fixing structure on the space block with three screws.
- Third, put the base on the structure to lock it.
- Fourth, fix the Base Fixing structure on the base with three screws.
- Fifth, change the battery cover of DX8000 and put DX8000 on the base to lock it.

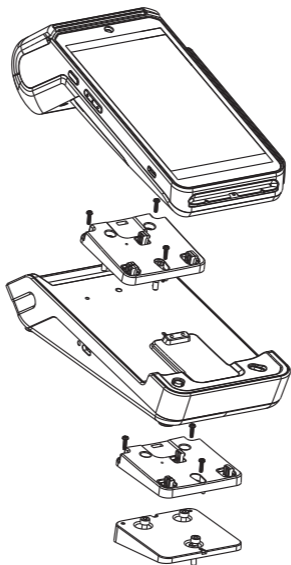

- If we want to unfix the base and DX8000, we can use screwdriver to push the area of the structure to unfix them.

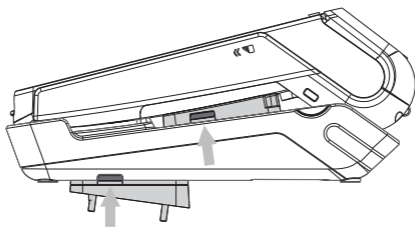

## 6. FAQs

**Q1:** The base fails to connect DX8000.

- Cause1: DX8000 WLAN is not yet opened.
- Solution: Open WLAN via the drop-down box of DX8000.
- Cause 2: DX8000 is placed too far away from base.
- Solution: Place and pair the devices within 10 meters.
- Cause 3: The password of DX8000 base is changed .
- Solution: Input the correct password , or restore factory setting to get the default password.

**Q2:** It displays that base is not connected to DX8000, while the green indicator light of base flashes.

- Cause1: The two devices are too far away from each other that its connection fails.
- Solution: Place the two devices near, better within 10 meters.
- Cause 2: The DX8000 is not paired to the base.
- Solution: Only one DX8000 can be paired to the base at the same time .The paired DX8000 may not be this one. We can pair this DX8000 to the base according to Q4.

**Q3:** Device plugged in USB port cannot be recognized.

- Cause: The USB port only supports for products of company such as the scanning gun (e.g. BR200-B) , scanning box(e.g.DCS20), E830MIS, and USB devices of serial ports such as CH34x, PL230, FTDI, CP210X. Other devices are not supported for now.
- Solution: If new USB devices need to be developed, please consult after-sales personnel.

**Q4:** How to pair one paired base with another DX8000?

- Solution: After powering on the base, long press on [Pairing] button for 3 secs. After that, the base is in “unpaired” status with red indicator light on. Perform pairing operations on DX8000. The base only save the information of latest DX8000 successfully paired with.

**Q5:** It cannot be recognized when the base connects to PC/ECR by USB TYPE-B port.

- Cause: It requires a CH340 driver to be installed on PC/ECR.
- Solution: For Windows, supported versions include 11/10/8.1/8/7/VISTA/XP/2000/98. And almost Windows 11/10 with Internet connected, the driver can be automatically installed once device connects to PC at the first time. Other Windows variants are also supported, include Windows Server (2022/2019/2016/2012/2008/2003), Windows Embedded and Windows IoT.

For macOS and Android, there are available drivers, but needs to be installed manually.

For Linux version is higher than 2.6.32 (or equal to 2.6.32), there is available driver just inside OS. But a few Linux versions which are customized (driver may be removed) need to install manually. And for Linux which version is lower than 2.6.32, it also needs to be installed manually.

More details please consult after-sales personnel.



## 7. Notes

- Prevent the terminal from sun exposure, high temperature, moisture and other mean conditions.
- Cut off the power before cleaning the device and wipe the main body with dry cloth.
- When the following abnormal phenomena occur, stop running the device immediately, cut off the power supply, and report to the service provider as soon as possible:
  - 1) Harsh noise heard during operation.
  - 2) Impurities or water found in the machine.
  - 3) Unpleasant smell found during operation.

## 8. Delivery and Storage

Deliver the device in normal way, avoiding rain and snow, sun exposure and mechanical impact. The product should be stored in the original box. The box should be at least 15cm away from the floor, at least 50cm from the wall, heat source, cold source, window or air inlet.

## 9. Power Adapter

The base can only be connected to the power adapter which is provided with AXIUM DX8000-BASE-W1 .

### **WARNING**

The power adapter provided is specially designed for ingenico AXIUM DX8000-BASE-W1. Do not use any other power supply. The use of a power supply with apparently similar voltage/current characteristics may damage your terminal.

RF exposure

The antenna of the product, under normal use condition is at least 20cm away from the body of the user. Warning statement to the user for keeping 20cm separation distance and the prohibition of operating to a person has been printed on the user manual. So, this product under normal use is located on electromagnetic far field between the human body.

## 10. Standard

### **CE Marking**

The CE marking indicates AXIUM DX8000-BASE-W1 complies with the requirements of European Directive 2014/53/EU on Radio Equipment for:

The protection of the health and the safety of the user and any other person.

The protection requirements with respect to electromagnetic compatibility.

And complies with harmonized standards.

Operating Frequency Band (RF):

TX Frequency:2412-2472MHz(802.11 b/g/n HT20),2422-2462MHz(802.11 n HT40)

RX Frequency:2412-2472MHz(802.11 b/g/n HT20),2422-2462MHz(802.11 n HT40)

Max. Of Transmit power:

16.66dBm (802.11 b), 15.97dBm (802.11 g), 14.28dBm (802.11 n HT20), 13.75dBm (802.11 n HT40)

## Environment (WEEE, Batteries and packaging)

This product is labeled in accordance with European Directives 2012/19/EU concerning Waste Electrical and Electronic Equipment (WEEE) and 2013/56/EC concerning Batteries and Accumulators. Those provisions are requiring producers and manufacturers to become liable for take-back, treatment and recycling upon end of life of equipment and batteries.

### THE PRODUCT



The crossed-out waste bin stuck on the product or its accessories means that the product belongs to the family of electrical and electronic equipment, and waste batteries must not be thrown away but collected separately and recycled.

Please contact your retailers for more detailed information about the

compliance solution in place for disposing of your old product and used batteries.

Packaging waste must also be collected separately to assure a proper disposal and recycling.

In this way you can participate in the re-use and upgrading of Electrical and Electronic Equipment Waste, which can have an effect on the environment and human health.

"INGENICO is a trademark of BANKS AND ACQUIRERS INTERNATIONAL HOLDING . This Document is Copyright © 2023 BANKS AND ACQUIRERS INTERNATIONAL HOLDING . BANKS AND ACQUIRERS INTERNATIONAL HOLDING retains full copyright ownership, rights and protection in all material contained in this document. The recipient can receive this document on the condition that he will keep the document confidential and will not use its contents in any form or by any means, except as agreed beforehand, without the prior written permission of BANKS AND ACQUIRERS INTERNATIONAL HOLDING. Moreover, nobody is authorized to place this document at the disposal of any third party without the prior written permission of BANKS AND ACQUIRERS INTERNATIONAL HOLDING. If such permission is granted, it will be subject to the condition that the recipient ensures that any other recipient of this document, or information contained therein, is held responsible to BANKS AND ACQUIRERS INTERNATIONAL HOLDING for the confidentiality of that information. Care has been taken to ensure that the content of this document is as accurate as possible. BANKS AND ACQUIRERS INTERNATIONAL HOLDING however declines any responsibility for inaccurate, incomplete or outdated information. The contents of this document may change from time to time without prior notice, and do not create, specify, modify or replace any new or prior contractual obligations agreed upon in writing between BANKS AND ACQUIRERS INTERNATIONAL HOLDING and the user. BANKS AND ACQUIRERS INTERNATIONAL HOLDING is not responsible for any use of this device, which would be non-consistent with the present document. All trademarks used in this document remain the property of their rightful owners"